



# SUBMITTING ELECTRONIC ARTWORK

## Accepted Formats

### Macintosh:

- InDesign (top choice)
- Illustrator
- Photoshop
- QuarkXpress

### PC:

- Illustrator
- Photoshop

## To Avoid Extra Charges and Delays...

- Include a hard copy composite of artwork.
- Make sure all Photoshop files are in CMYK or duotone mode.
- Create your file in the ADS Printing template, or adhere exactly to ADS Printing Measurements.
- We recommend rasterized graphics have a minimum resolution of 300 DPI.
- Include an EPS version of all graphics files.
- Include center and four outer registration marks.
- Before sending files via e-mail or FTP, please inform your ADS account manager so that we may route your files quickly and correctly.

## Please Include...

- Completed ADS Electronic Prepress form. Be sure to fill in contact person and phone number.
- Diskette, 100 MB ZIP, or CD-R with identification label.
- Hard copy composite and separations of artwork (separations are not required but highly recommended).
- All screen and printer fonts used in both layout and graphics documents.
- All supporting or embedded graphics used.

## Please Remember...

- Any halftones lighter than 18% will not print, and any halftones darker than 90% will appear as solid.
- Colors will appear darker without a white flood (especially halftones).
- Text can be no smaller than 5 pts (6 pts. when reversed).
- There are no bleeds required. Do not extend artwork past ADS Printing Measurements.
- If sending files via electronic mail (not recommended for files larger than 3MB), please send directly to your Customer Service Representative. We suggest stuffing and binhexing the files.
- We are always available to answer any of your questions!

## Printing Measurements

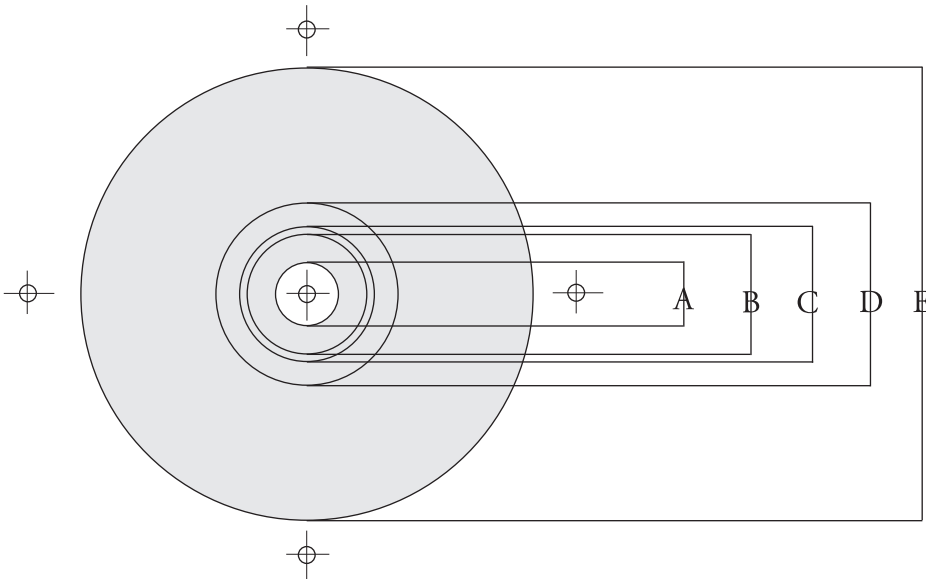

- Drawing is not to scale. Do not use as a template.
- Shaded areas represent printable areas of the CD.
- Dimension D represents the edge of the mirror band around the center hub. We recommend using this as your inner dimension if your artwork is text only or contains small graphics with much of the actual CD showing through.
- Following these measurements exactly will allow you to use an ADS generic flood rather than outputting an extra piece of film.

DIMENSION	MILLIMETERS	INCHES
A	20	.7874
B	33	1.299
C	37	1.457
D	45	1.772
E	117.45	4.62

### The ADS Group Campus

2155 Niagara Lane North • Suite 120 • Plymouth, MN 55447 • tel 763.449.5500 • toll free 800.759.0992 • fax 763.449.5555

[www.theadsgrouppifference.com](http://www.theadsgrouppifference.com)

CS-101-14 REV. 2.1